

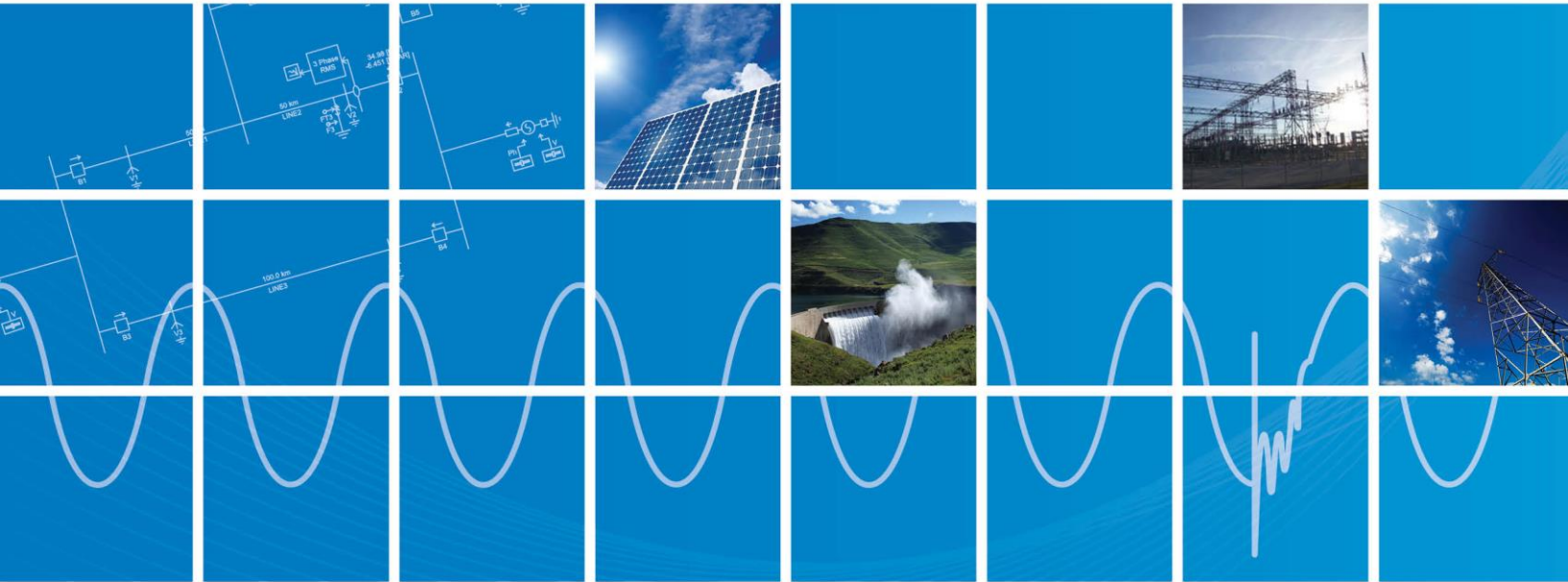

PSCAD™

IEEE 39 Bus System

May 22, 2018
Revision 1



Powered by Manitoba Hydro International Ltd.
211 Commerce Drive
Winnipeg, Manitoba
R3P 1A3 Canada
mhi.ca





Contents

1.0	Objective	1
2.0	Validation	5
3.0	PSCAD Case Set-up Instructions.....	6
4.0	Future updates to the system model.....	6
5.0	Technical References	6
	Appendix 1	7

1.0 Objective

IEEE bus systems are used by researchers to implement new ideas and concepts. This technical note describes the details of the IEEE 39-bus system [1]. The system consists of loads, capacitor banks, transmission lines, and generators. Figure 1 depicts part of the PSCAD model of IEEE 39-bus system.

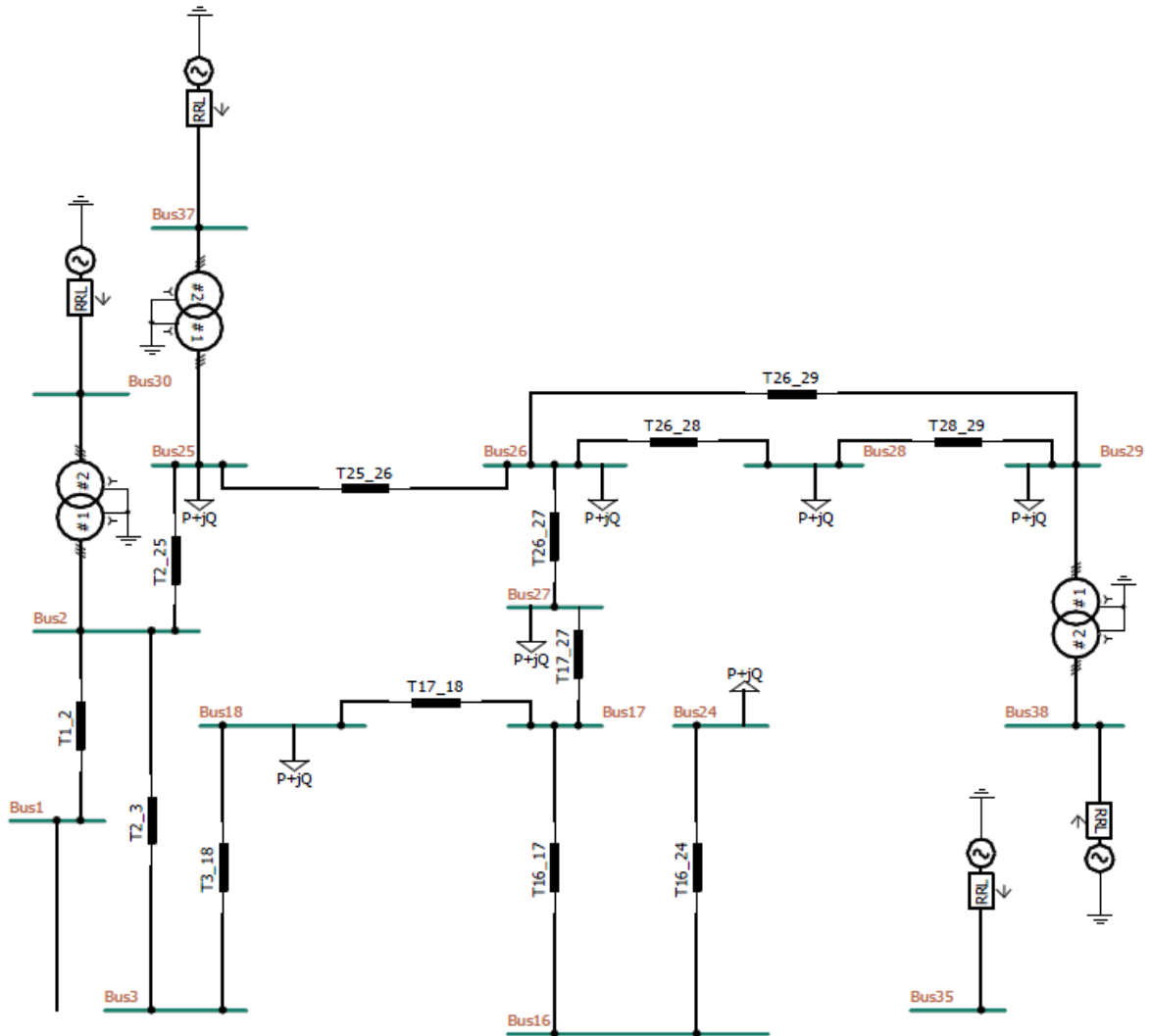

Figure 1 – PSCAD Model of IEEE 39-bus system

Each machine (generator) is represented as a voltage source where its source impedance is set arbitrarily as 10 Ohms. Table 1 summarizes the setting for each source, with a base of 100 [MVA] for per unitizing.

Table 1 - Terminal conditions of IEEE 39-bus system

Bus	V [kV]	δ [deg]	P [pu]	Q [pu]
31	225.860	-1.590	5.713	3.639
30	240.925	-3.730	2.500	0.832
32	226.113	1.790	6.500	0.015
33	229.356	2.870	6.320	0.697
34	232.829	1.460	5.080	1.488
35	241.339	4.780	6.500	1.670
36	244.605	7.460	5.600	0.754
37	236.394	2.050	5.400	-0.353
38	236.095	7.300	8.300	-0.005
39	236.900	-10.06	10.00	-0.365

Transmission lines are modelled using the Bergeron model. Table 2 summarizes the transmission line parameters.

Table 2 - Transmission line characteristics of IEEE 39-bus system

Line		R [$\mu\text{u/m}$]	X [$\mu\text{u/m}$]	B [$\mu\text{u/m}$]
From Bus	To Bus			
1	2	0.0035	0.0411	0.6987
1	39	0.0010	0.025	0.7500
2	3	0.0013	0.0151	0.2572
2	25	0.0070	0.0086	0.1460
3	4	0.0013	0.0213	0.2214
3	18	0.0011	0.0133	0.2138
4	5	0.0008	0.0128	0.1342
4	14	0.0008	0.0129	0.1382
5	6	0.0002	0.0026	0.0434
5	8	0.0008	0.0112	0.1476
6	7	0.0006	0.0092	0.1130
6	11	0.0007	0.0082	0.1389
7	8	0.0004	0.0046	0.0780
8	9	0.0023	0.0363	0.3804
9	39	0.0010	0.0250	1.2000
10	11	0.0004	0.0043	0.0729
10	13	0.0004	0.0043	0.0729
13	14	0.0009	0.0101	0.1723
14	15	0.0018	0.0217	0.3660
15	16	0.0009	0.0094	0.1710
16	17	0.0007	0.0089	0.1342
16	19	0.0016	0.0195	0.3040
16	21	0.0008	0.0135	0.2548
16	24	0.0003	0.0059	0.0680
17	18	0.0007	0.0082	0.1319
17	27	0.0013	0.0173	0.3216
21	22	0.0008	0.0140	0.2565
22	23	0.0006	0.0096	0.1846
23	24	0.0022	0.0350	0.3610
25	26	0.0032	0.0323	0.5130
26	27	0.0014	0.0147	0.2396
26	28	0.0043	0.0474	0.7802
26	29	0.0057	0.0625	1.0290
28	29	0.0014	0.0151	0.0249

Loads are modelled as a constant PQ load with parameters as shown in Table 3.

Table 3 - Load characteristics of IEEE 39-bus system

Bus	P [pu]	Q [pu]
3	3.220	0.024
4	5.000	1.840
7	2.338	0.840
8	5.220	1.760
12	0.075	0.880
15	3.200	1.530
16	3.294	0.323
18	1.580	0.300
20	6.800	1.030
21	2.740	1.150
23	2.475	0.846
24	3.086	-0.922
25	2.240	0.472
26	1.390	0.170
27	2.810	0.755
28	2.060	0.276
29	2.835	0.269
31	0.092	0.046
39	11.04	2.500

2.0 Validation

The PSCAD model was validated against the PSS/E power flow values from [1]. Table 4 depicts the line and source power flow comparison.

Table 4 - Source and line power comparison of IEEE 39-bus system

Bus		PSS/E		PSCAD	
		P [pu]	Q [pu]	P [pu]	Q [pu]
30		2.500	0.832	2.483	0.808
31		5.713	3.639	5.702	3.645
32		6.500	0.015	6.489	0.020
33		6.320	0.697	6.303	0.767
34		5.080	1.488	5.047	1.522
35		6.500	1.670	6.497	1.642
36		5.600	0.754	5.590	0.792
37		5.400	0.353	5.397	0.312
38		8.300	0.005	8.293	0.059
39		10.00	0.365	9.988	0.381
From Bus	To Bus				
1	2	1.164	0.470	1.175	0.483
1	39	1.162	0.470	1.176	0.483
2	3	3.647	-0.135	3.651	-0.136
2	25	2.357	-1.111	2.349	-1.057
3	4	0.752	-0.295	0.766	-0.267
3	18	0.341	-0.245	0.350	-0.216
4	5	1.635	1.042	1.625	-1.015
4	14	2.613	-0.375	2.612	-0.377
5	6	4.828	-0.088	4.821	-0.114
5	8	3.181	1.173	3.192	1.175
6	7	4.257	1.230	4.257	1.225
6	11	3.479	-1.573	3.478	-1.589
7	8	1.918	0.389	1.919	0.386
8	9	0.121	0.072	0.119	0.074
9	39	0.121	0.351	0.119	0.349
10	11	3.498	1.139	3.501	1.133
10	13	2.994	0.280	2.989	0.263
13	14	2.922	-0.051	2.916	-0.092
14	15	0.303	0.513	0.292	-0.475
15	16	2.904	0.626	2.909	0.661
16	17	2.038	-0.483	2.028	-0.493
16	19	4.545	0.043	4.517	0.066
16	21	3.297	-0.511	3.295	-0.529

16	24	0.427	0.736	0.430	0.729
17	18	1.921	-0.298	1.933	0.271
17	27	0.115	-0.186	0.094	-0.134
21	22	6.046	0.688	6.070	0.666
22	23	0.427	0.397	0.439	0.345
23	24	3.513	0.258	3.517	0.265
25	26	0.784	-0.244	0.765	-0.279
26	27	2.704	0.585	2.716	0.452
26	28	1.415	-0.672	1.430	-0.648
26	29	1.922	-0.788	1.951	-0.768
28	29	3.491	-0.396	3.490	-0.372

3.0 PSCAD Case Set-up Instructions

Dependencies

This example is compatible with PSCAD v4.5.3 and beyond. The files

required to run the tutorial are as follows:

- New_IEEE_39_CT.pscx

4.0 Future updates to the system model

- Replace the voltage sources with detailed machine models for dynamic analysis.
- Update short circuit levels of each source to represent specific system strengths.

5.0 Technical References

[1] [Online]. Available FTP: http://psdyn.ece.wisc.edu/IEEE_benchmarks

[2] http://sas.ieee.ca/pesias/seminar_slides/IEEE_PES-IAS_Chapter_24_01_13.pdf

Appendix 1

The line resistances and reactances are provided in [1] for each line segment of the test system. The following table lists the approximate line length of each segment, based on typical line data (as listed in Table A-2).

Table A-1- Approximate line lengths based on typical line reactance values as shown in Table A-2

From Bus	To Bus	Total Reactance (Ω)	Approximate length of the line based on typical line reactance values (km)
1	2	21.7419	43.4838
1	39	13.2250	26.4500
2	3	7.9879	15.9758
2	25	4.5494	9.0988
3	4	11.2677	22.5354
3	18	7.0357	14.0714
4	5	6.7712	13.5424
4	14	6.8241	13.6482
5	6	1.3754	2.7508
5	8	5.9248	11.8496
6	7	4.8668	9.7336
6	11	4.3378	8.6756
7	8	2.4334	4.8668
8	9	19.2027	38.4054
9	39	13.225	26.4500
10	11	2.2747	4.5494
10	13	2.2747	4.5494
13	14	5.3429	10.6858
14	15	11.4793	22.9586
15	16	4.9726	9.9452
16	17	4.7081	9.4162
16	19	10.3155	20.6310
16	21	7.1415	14.2830
16	24	3.1211	6.2422
17	18	4.3378	8.6756
17	27	9.1517	18.3034
21	22	7.4060	14.8120
22	23	5.0784	10.1568
23	24	18.5150	37.0300
25	26	17.0867	34.1734
26	27	7.7763	15.5526

26	28	25.0746	50.1492
26	29	33.0625	66.1250
28	29	7.9879	15.9758

Table A-2- Typical line reactance values

Voltage (kV)	R(Ω /km)	X(Ω /km)
72	0.41	0.5
138	0.14	0.5
230 (single)	0.09	0.5
230 (bundled)	0.04	0.4
345 (bundled)	0.03	0.3
500 (bundled)	0.02	0.3



DOCUMENT TRACKING

Rev.	Description	Date
0	Initial	30/Dec/2014
1	Update to new brand guidelines	22/May/2018

Copyright © 2018 Manitoba Hydro International Ltd. All Rights Reserved.
