



July 2009 Issue...

- 1** Evaluation of the Robustness to Grid Disturbances at the Nuclear Power Plant of Ringhals
- 6** Investigation of Stray Voltage Problems Near a Low Voltage Distribution Station
- 9** A Novel Variable Speed Cage Induction Generator – Concept Verification through Simulation
- 12** Method for Studying and Mitigating the Effects of Wind Variability on Frequency Regulation
- 15** The *neXus Engine*...
- 16** PSCAD® 2009 Training Sessions

Evaluation of the Robustness to Grid Disturbances at the Nuclear Power Plant of Ringhals

Magnus Knutsson, Ringhals AB, and Andreas Petersson, Gothia Power AB

On the 25th of July 2006, an incident occurred at unit 1 at Forsmark nuclear power plant (NPP) in Sweden. The incident was initiated by a phase-to-phase short circuit in the Forsmark 400-kV switch yard. The short circuit was followed by a load rejection when the unit circuit breaker was opened. The combination of a short circuit and a load rejection caused an unexpected behavior of emergency-power system of the NPP.

The short circuit was caused by a maintenance fault in the switch yard and the fault was cleared by the back-up undervoltage protection of the power plant after about 300 ms. After the load rejection, the power plant entered island operation with only house-load consumption. After the fault clearance, a fundamental-frequency overvoltage occurred, caused by the generator and the excitation system which affected all four divisions of the emergency power supply. Each division contains an uninterruptable power supply (UPS) that is used for supplying the low voltage AC system without any interruptions. The overvoltage caused a failure in the UPS systems on two of the four divisions about 2 seconds after the fault clearance. Still, there is no explanation why only two of the UPS systems failed and not all four. For different reasons, entering island operation was unsuccessful and therefore all diesel generators were started for the back-up supply of the safety busbars. However, the diesel generators at Forsmark relied upon the UPS voltage in order to connect the diesel

generator to the safety busbars. This means that only two diesel generators were connected to their corresponding safety busbars and thereby two out of four divisions were inoperable [1]. Interesting to note is that originally the UPS system consisted of rotating converters, which in comparison to static converters can be considered to be more robust against overvoltages. During modernization of the NPP, the rotating converters have been replaced with static converters.

In the days following the Forsmark incident, the UPS systems of the other NPPs in Sweden were thoroughly investigated. This led to a decision to take two of the Oskarshamn NPP reactors out of operation, since they were deemed not ready for operation. This means that in autumn of 2006, three out of ten reactors in Sweden were out of operation and disconnected from the grid due to the incident in Forsmark. In addition, there were other reactors out of operation due to annual outage.

The incident in Forsmark was rated level 2 on the INES scale. Events are classified on the scale at seven levels: Levels 1–3 are called “incidents” and Levels 4–7 “accidents.” The scale is designed so that the severity of an event is about ten times higher for each increase in level on the scale. Events without safety significance are called “deviations” and are classified Below Scale / Level 0 [2].

The incident at Forsmark NPP has led to an intensive effort to evaluate the robustness of the Swedish NPPs regarding disturbances caused by the electrical system. The aim of this document is to show some examples of how Ringhals NPP has used PSCAD®/EMTDC™ as the simulation tool during their evaluation of the NPP's robustness towards electrical and grid disturbances. The Ringhals NPP is located at the west coast of Sweden and constitutes four nuclear reactors with a total rated electrical power of 3700 MW.

Analysis in PSCAD®/EMTDC™ In order to study how different electrical disturbances influence the Ringhals NPP, a simulation model was built in PSCAD®. Initially, the major concern has been to determine the amount of fundamental frequency overvoltage that can be expected when a fault is cleared with the unit breaker and the generator enters island operation.

The electrical system of the four Ringhals reactors and the nearby connecting grid has been modeled, as shown in Figure 1.

Figure 2 shows the electrical system model of one of the reactors. As seen in the figure, each reactor consists of two turbines/generators. To each generator, two redundant divisions (four in total) for the auxiliary supply are connected. In the PSCAD® model,

one division of each nuclear reactor is modeled in more detail with all larger induction motors and an equivalent induction motor for all low-voltage induction motors. The other division connected to the same generator only has one equivalent induction motor as a load. For the other generator, the two divisions have been modeled as static loads.

When analyzing the robustness of the Ringhals NPP against electrical disturbances, the following aspects have been considered:

- Phase to earth faults and phase to phase faults (short circuits) and fault locations;
- Excitation system control mode;
- Protection system;
- Protection system failure;
- Induction motor loads;
- Operating conditions; and
- Faults in the excitation system.

In order to account for all of these contingencies, several hundreds of simulations were performed. The multiple-run component in PSCAD® provided a nice way of performing batch simulations.

As an example of a typical simulation result, which is close to the Forsmark incident, see Figure 3. In the figure, a three-phase short circuit is applied on the

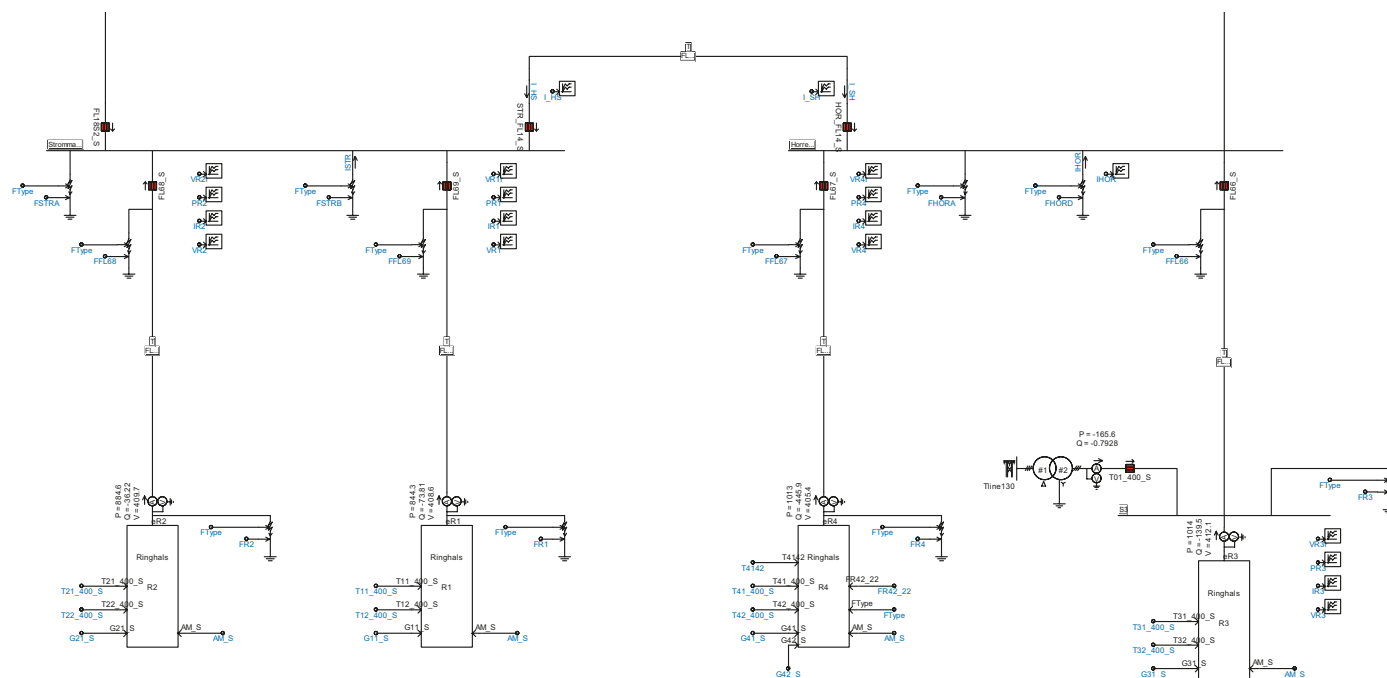
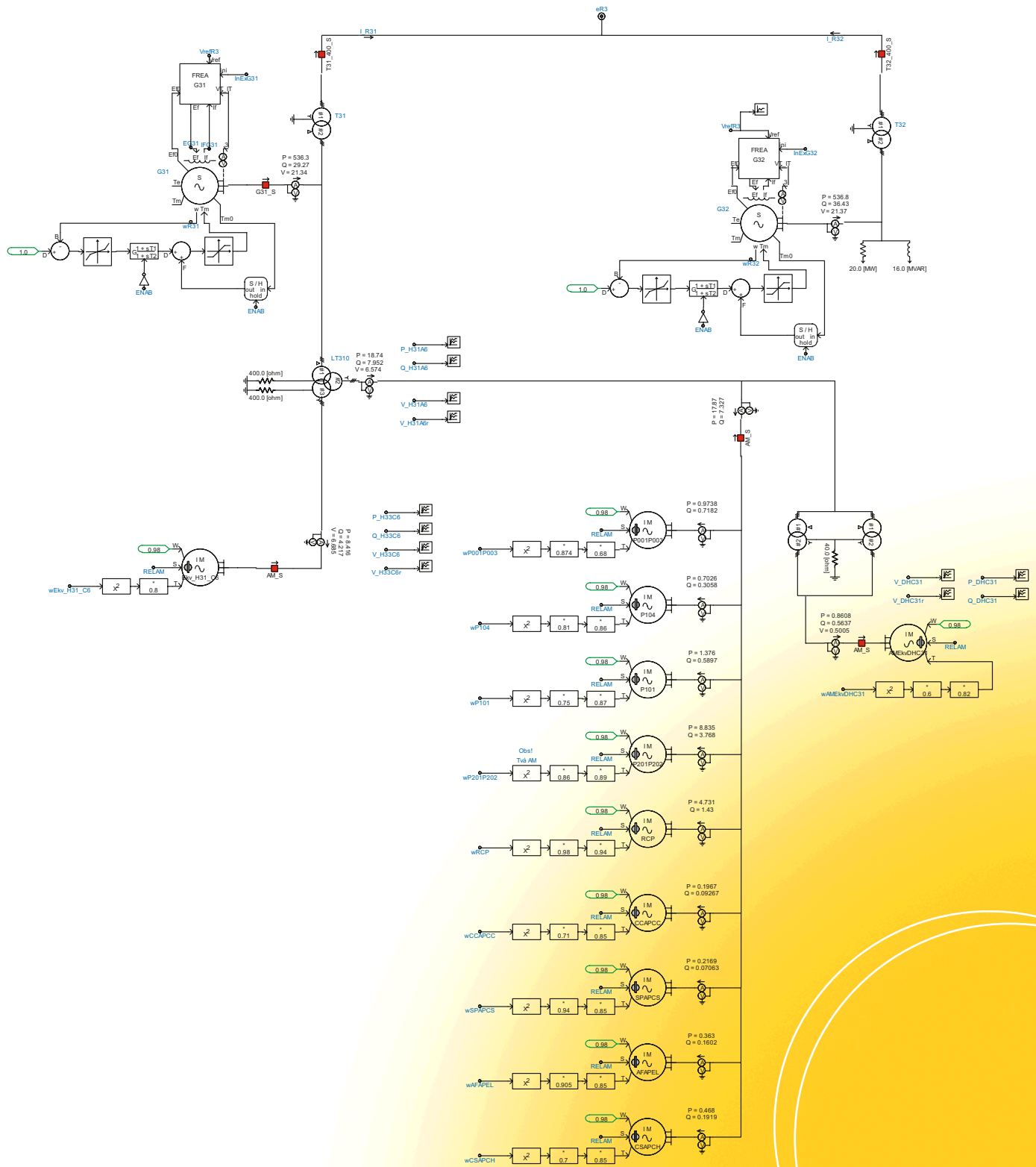

Figure 1 Simulation model of the Ringhals NPP and the nearby (400/130 kV) grid.

Figure 2 Simulation model for one of Ringhals' four reactors. One nuclear reactor consists of two turbines/generators and four redundant divisions for the auxiliary supply. Note that two of the divisions are only modeled as impedance loads.



400 kV busbar outside Ringhals unit 4. After 100 ms, the fault is cleared by the unit breaker and the unit enters island operation. The generator (rms) voltage and the produced active and reactive power in the generator is shown in the figure. The generators of the Ringhals unit 4 have a rotating excitation system.

As seen in Figure 3, during the short circuit, the voltage drops to approximately 25% of the nominal value on the generator terminal. When the voltage is low, the excitation system tries to inject more reactive power to increase the generator busbar voltage.

When the unit breaker is then opened, the fault is cleared and the voltage recovers. However, at this time, the generator is overexcited and an overvoltage is generated until the excitation system has restored the voltage to nominal.

In Figure 3, the generator's excitation system is in automatic voltage regulation (AVR) mode.

In some rare situations (e.g. during maintenance or failure in the excitation system), the generator's excitation system may be in field current regulation (FCR) mode.

The excitation system can change operating mode from AVR to FCR during operation without transients. Figure 4 shows a corresponding simulation where the control mode has been changed to FCR before the short circuit and the load rejection. This means that the pre-fault operation condition is close to identical in Figures 3 and 4 except for the excitation system control mode.

As seen in Figure 4, when the excitation current is kept constant after the load rejection, the generator voltage will increase significantly.

When analyzing the robustness of the Ringhals NPP, the voltage at different busbars (20 kV, 6.6 kV and 500 V) of the power plant has been studied for all of the investigated simulation cases.

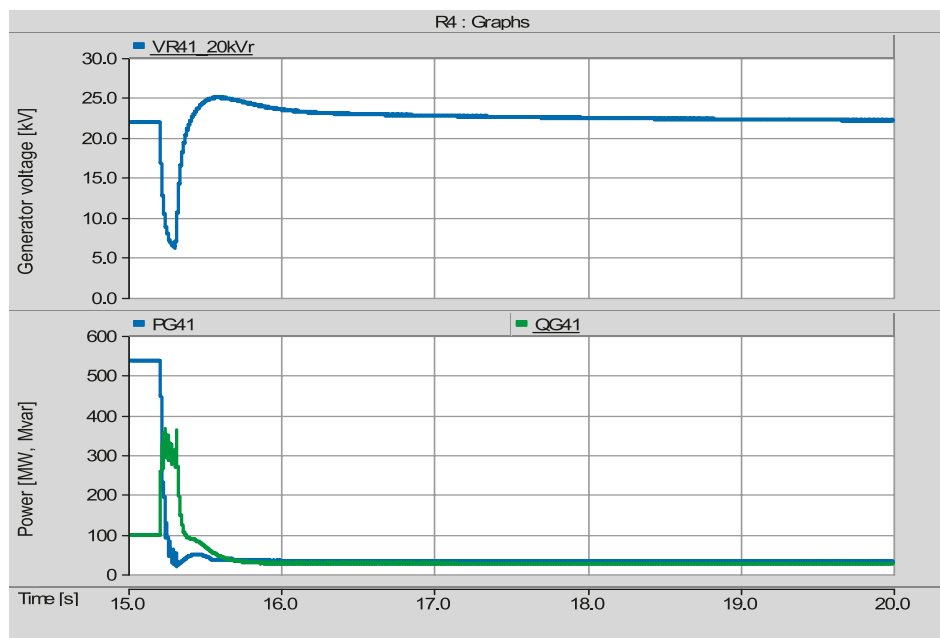

Figure 3 Generator voltage (top) and active and reactive power (bottom) during a short circuit and load rejection. The generator excitation system is operating in automatic voltage regulation (AVR) mode.

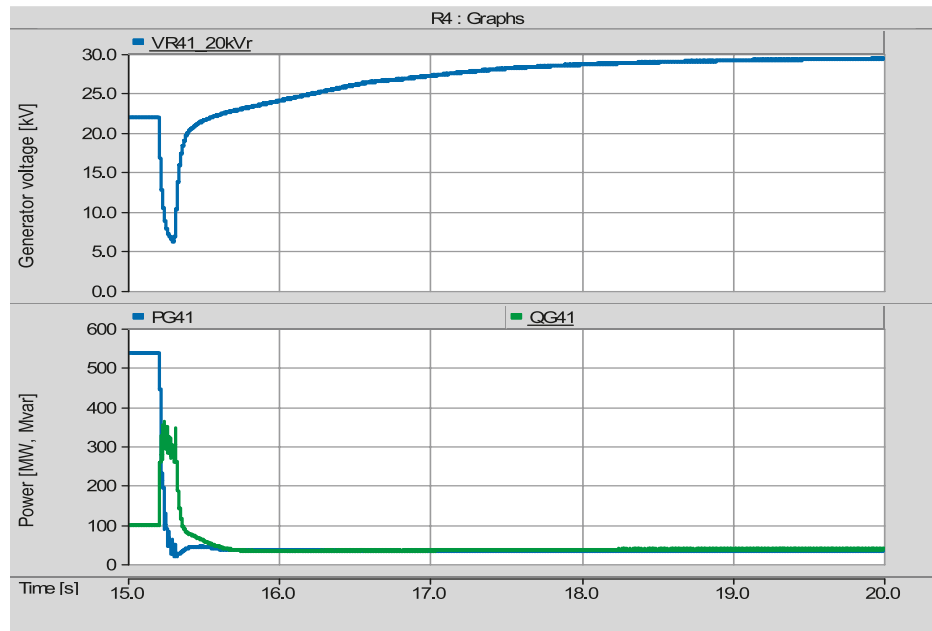

Figure 4 Generator voltage (top) and active and reactive power (bottom) during a short circuit and load rejection. The generator excitation system is operating in field current regulation (FCR) mode.

From all of these simulations, the voltages at different voltage levels were put together and compared against dimensioning criteria and overvoltage protection system settings.

From the analysis, it was concluded, among others, that:

- The generator and its operating conditions play an important role in the voltage behaviour after the load disconnection;
- A static excitation system is faster than a rotating excitation system and therefore the overvoltage may be less for a static system. The control mode (AVR or FCR) of the excitation system is also essential;
- Protection system, its settings and coordination is crucial;
- Saturation of generators and transformers may reduce the overvoltage; and
- Induction motor loads act as “low-pass filters” and reduce overvoltages at lower voltage levels in the power plant.

Conclusions PSCAD® has been a fast and efficient way of performing the desired simulations. The results of the simulations have been used when evaluating the robustness of the Ringhals NPP against electrical disturbances like the one at Forsmark. Moreover, the simulation results have contributed to increase the knowledge at Ringhals NPP regarding the investigated phenomenon.

References

- [1] “Defense in Depth of Electrical Systems and Grid Interaction,” Final DIDEISYS Task Group Report, Draft version, www.nea.fr/html/insd/csni/didelsys.html
- [2] www.iaea.org

If anyone would like to discuss the article further, please feel free to contact the authors at:
magnus.knutsson@vattenfall.com
andreas.pettersson@gothiapower.com

Investigation of Stray Voltage Problems Near a Low Voltage Distribution Station

Rajitha Perera, Jared Waddell, and Ken Burr, Distribution Performance, Manitoba Hydro

In August 2008, Distribution Performance Engineering of Manitoba Hydro were informed of an issue related to Stray Voltage at the Windsor Park Swimming Pool. The Power Quality Section of Business Engineering Service Department was also actively involved to assess the nature of the problem. Various measurements at the Windsor Park Pool and also at other neighbouring commercial customers were recorded to further analyse the problem.

The pool is located around 100m from a distribution station and is fed from two 24 kV feeders. The station has two 8 MVA transformers and eight (8) 4 kV feeders feeding the residential/commercial customers in the neighbourhood. Three 50 kVA 3-Phase Wye-Wye transformers located just outside the fence of the station feed the neighbouring school and swimming pool.

According to the initial measurements, the NEV was recorded around 1.9 Volts and earth current was recorded around 3A when the supply was cut off to the pool. Since some preliminary actions did not resolve the problem, a detailed PSCAD® study was undertaken. The field measurement values were used (specifically 4 kV feeder currents, neutral currents, harmonic content, earth currents and NEV) to verify the results of the PSCAD® model and tune the model to represent the distribution system accurately.

The PSCAD® study considered four possible mitigating methods. The study indicated that the 'Ronk Blocker' (Saturable Reactor) would be the most suitable and cost effective solution to the stray voltage problem at the pool. The total cost of installing the Ronk Blocker to the existing transformer is around \$1,500/-

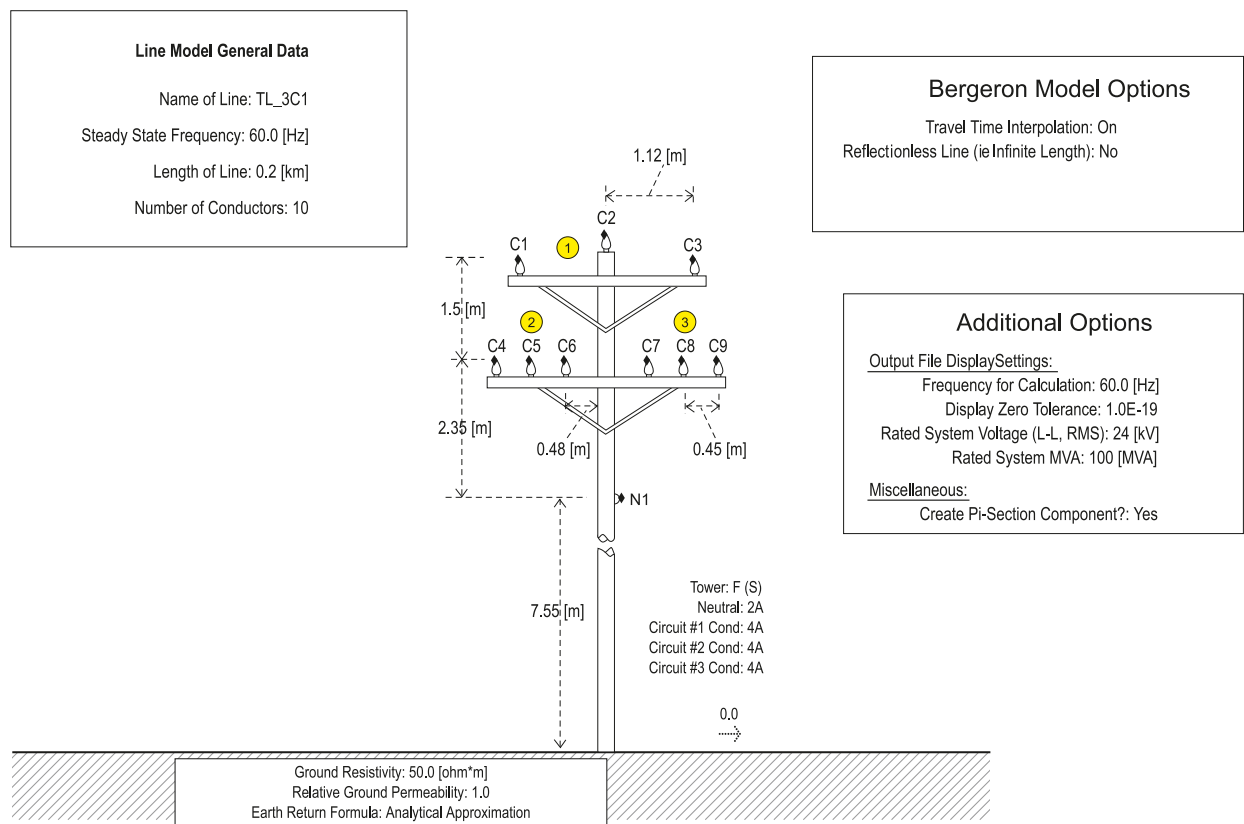

Figure 1 Manitoba Hydro distribution pole represented on PSCAD®

Development of the PSCAD® Model

The development of the complete model of the system at Windsor Park can be identified in three stages.

Stage 1 In the first stage, the Manitoba Hydro poles with 24 kV line and two 4 kV under-built systems were modeled. Since the feeders are too short, Pi (π) line models were created from the different pole configurations with correct feeder lengths (PSCAD® can generate the Pi model data for a given pole configuration). The rest of the system was modeled using PSCAD® standard library components (Figure 1).

Stage 2 It was determined during the investigation, that the system neutral carries a high amount of harmonic current (3rd harmonic and also other odd harmonics, especially 5th and 9th harmonics). It was assumed that the high harmonic content is due to the non-linear loads, such as power supplies, lighting (CFL lamps) and dimmer circuits. Single-phase, full-wave rectifier circuits were used to model the injection of harmonics to the system. Variable loads (inductors and resistors) were used to adjust the feeder currents until the values were matched with the measured currents. The system was fine tuned until proper load flow was achieved, including the measured stray voltage, ground and neutral currents at the pool (Figure 2 - system model).

Stage 3 In this stage, four different cases were studied as mitigating methods to resolve the stray voltage issue. A brief description of these four cases is as follows:

Case 1 – Replacing the existing Y-Y transformer by a Delta-Y transformer: Distribution transformer at the pool was modeled as a Delta-Y transformer while keeping the transformer for the school as a Y-Y. The standard practice of Manitoba Hydro is to connect the secondary neutral of Wye winding to the system neutral. Once this connection is made, it will provide a path for the stray currents to return to the source, via system neutral. This will not eliminate the stray voltage problem at the pool, when the secondary neutral is tied to the system neutral.

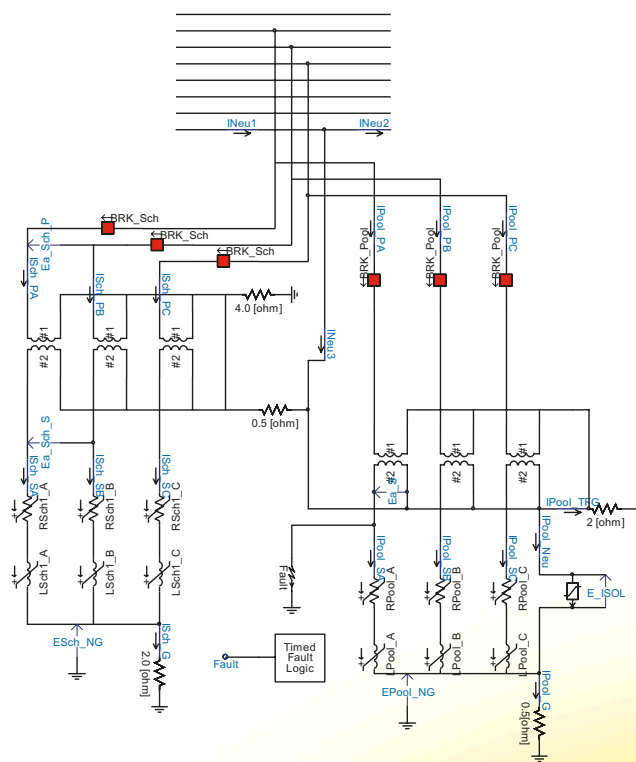

Figure 2 Part of the system model with the saturable reactor in place.

Case 2 – Connecting a series Current Balanced Transformer: This proved not to be suitable for three-phase systems.

Case 3 – Connecting an Isolator to the neutral wire, to isolate the system neutral from the customer neutral (open circuit under steady state, and short circuit during a fault). The Isolator was modeled in PSCAD® as a surge arrester with arrester rated voltage to 45V.

Case 4 – Connecting a Saturable Reactor to the neutral wire, to introduce high impedance during steady state and low impedance during a fault. This device (Saturable Reactor) operates directly on the principle of magnetic saturation and does not depend on external or internal logic controls. Therefore, it responds instantaneously, providing immediate continuous protection.

To model a saturable reactor in PSCAD®, a single-phase transformer is used by enabling saturation. The saturation voltage is assumed as 11 Volts, to match the characteristics of Ronk Stray Voltage Blocker, produced by Ronk Electrical Industries.

The simulated current and voltage waveforms with the saturable reactor are shown in Figure 3.

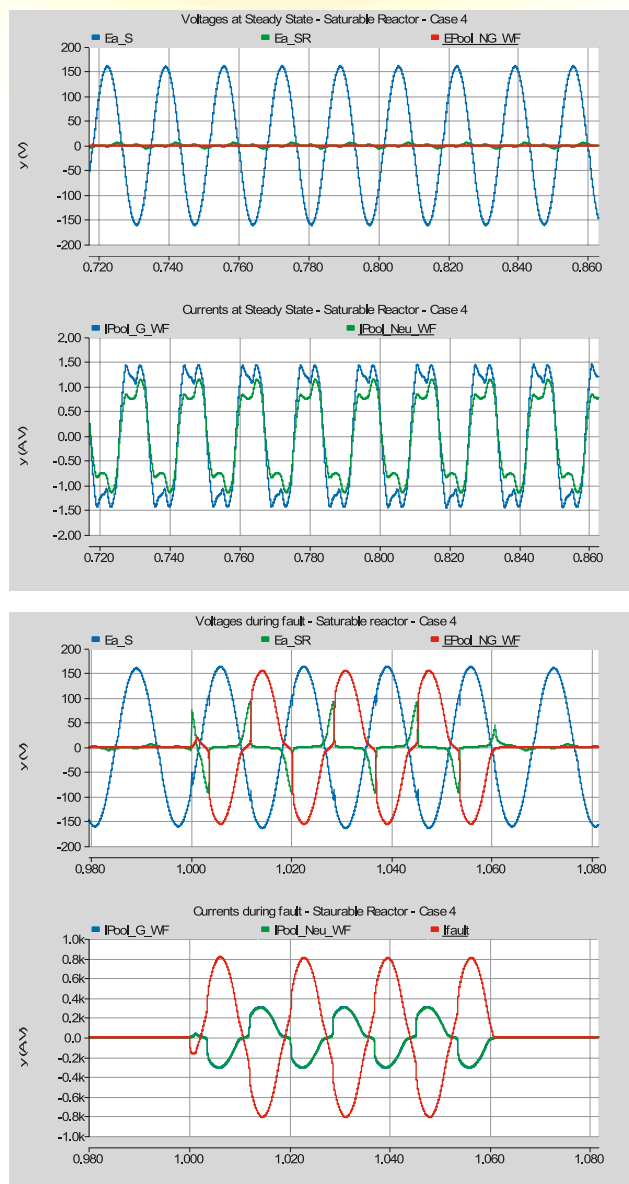

Figure 3 Steady state voltage and current waveforms near the pool with a saturable reactor.

System behaviour under steady state and fault conditions was analyzed for all four cases. Effect of the neutral isolator was also studied for Case1.

After careful consideration, the saturable reactor solution was implemented. The measurements at the pool site with and without the saturable reactor verified the solution method selected based on the PSCAD® study (Figure 4).

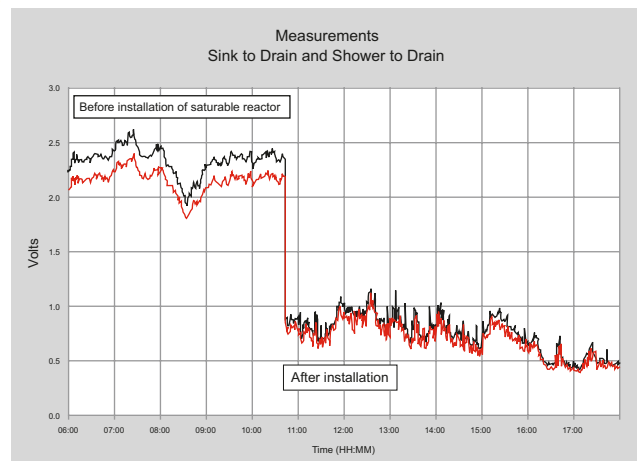

Figure 4 Stray voltage measurements with and without the saturable reactor.

If anyone would like to discuss the article further, please feel free to contact the authors at:

rperera@hydro.mb.ca
jwaddell@hydro.mb.ca
kburr@hydro.mb.ca

A Novel Variable Speed Cage Induction Generator – Concept Verification through Simulation

Udaya K. Madawala, Senior Member IEEE, and J. Bradshaw

A novel technique to generate power at constant frequency using a 3-phase cage induction motor, operated under variable speed conditions and without an intermediate inverter stage is discussed. The technique uses any one of the three stator windings of the motor as the excitation winding, and the remaining two windings, connected in series, as the power winding. The proposed two series-connected and one isolated (TSCAOI) winding configuration cancels out the mutual coupling between the excitation winding and the two windings connected in series, making them magnetically decoupled for independent control. Power is generated through the series connected two windings with appropriate excitation to the single winding at desired frequency when the rotor is driven either by a wind or hydro-turbine at variable speed. Either a simple single-phase square wave inverter or a reversible rectifier can be used to excite the single winding at the desired frequency of generation. Simulations are presented to prove the validity of the proposed technique, which is simple and requires no output filtering for grid-integration as harmonics from excitation inverter are filtered-out by the generator itself.

Introduction Amongst various renewable energy sources that are available, wind energy can be considered as a source that has been widely used. In these systems, various techniques have been employed within the system for mechanical to electrical energy conversion. Of these, cage induction generators are well known for their simplicity and low cost, and operated at constant rotor speed to generate power at constant frequency for both direct grid integration and stand alone operation. Usually they are excited (or rotor magnetization is provided) through a capacitor when operated at constant speed, and are incapable of tracking maximum power of a turbine at various wind speeds with varying rotor speeds unless an intermediate inverter stage is employed. Such an additional inverter stage is often found to not be economically justifiable for most applications.

This paper presents a novel technique whereby a 3-phase cage induction motor can be used as a generator under variable speed conditions without an intermediate inverter stage. The proposed technique is ideal for small scale applications but can equally be used for higher power levels, if necessary, and also for 3-phase power generation with three machines connected to the same turbine shaft. The viability of the proposed concept is investigated through simulations of a single 1 MW cage induction motor using PSCAD®.

The Proposed Technique The proposed technique configures the three stator windings of a typical 3-phase cage induction motor in a novel way to create a separate excitation winding and a power winding. In this configuration, any one of the three windings is used solely for excitation while the other two are connected in series to generate power at the desired frequency while the rotor is driven at any given speed. The proposed two series-connected and one isolated (TSCAOI) winding configuration of a 3-phase cage induction machine is shown in Figure 1. As shown in the following section, TSCAOI winding configuration magnetically decouples both excitation and power windings from each other, and thus allows for independent control as in the case of a single-phase induction motor with an auxiliary winding [1].

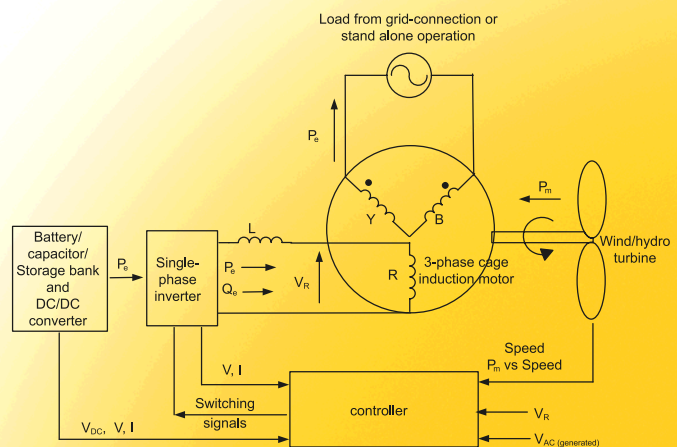

Figure 1 Proposed TSCAOI winding configuration.

The excitation can be achieved through either a square-wave inverter or a reversible rectifier. The former is the simplest, and can be operated at the desired generation frequency using a less sophisticated controller to provide the required reactive power of the generator. In the latter case, as shown in Figure 1, the system is more sophisticated and complex but facilitates bi-directional power flow, allowing for both energy storage and later retrieval. The level of excitation in both cases is determined by the voltage generated at the power winding. A controller, comprising a voltage feedback with phase-lock-loop (PLL), can be employed to regulate the excitation. The controller in the simplest form will provide only the reactive power requirement of the generator (not the load), and at a more sophisticated level can control both active and reactive power flow in accordance with the phase angle and voltage magnitude between the inverter and the stator voltage.

The proposed technique was tested on a lab machine (in open loop) for further validation.

Mathematical Model The machine equations of the TSCAOI winding configuration have been developed from the standard phase domain induction motor equations. These models define the behavior of the machine in terms of flux linkage between the windings of the machine, in the following form:

$$[V] = [R][I] + \frac{d[\psi]}{dt} \quad (1)$$

$$[\psi] = [L][I] \quad (2)$$

This apparently simple model form is complicated by the fact that the machine inductance matrix L will change depending on the angle of the machine shaft θ .

Under the proposed TSCAOI winding configuration, shown in Figure 1, noting certain special conditions for currents and voltages in different windings, the torque equation can be proved to be of the following form [2]:

$$T = \frac{3}{2} L_{ms} \begin{bmatrix} i_e & i_o \end{bmatrix} \begin{bmatrix} \sin(\theta_r) & \cos(\theta_r) \\ -\sqrt{3} \cos(\theta_r) & \sqrt{3} \sin(\theta_r) \end{bmatrix} \begin{bmatrix} i_{r\alpha} \\ i_{r\beta} \end{bmatrix} \quad (3)$$

PSCAD® Model In order to verify the validity of the proposed concept, the TSCAOI winding configuration is modeled in PSCAD® as shown in Figure 2. For initial investigations, a variable resistive load is connected across the series connected two windings, which serve as the power winding. The remaining third winding is excited as per current reference. A simple proportional-integral (PI) controller and a phase-lock-loop (PLL) are used in the control block. The magnitude of the current reference is derived according to the generated voltage error through the PI controller. The phase angle of the excitation current is forced to be 90 degrees lagging behind the excitation voltage through the PLL. This will ensure that the inverter, ideally, provides only the reactive power to the motor, which is required to maintain the desired output or generated voltage.

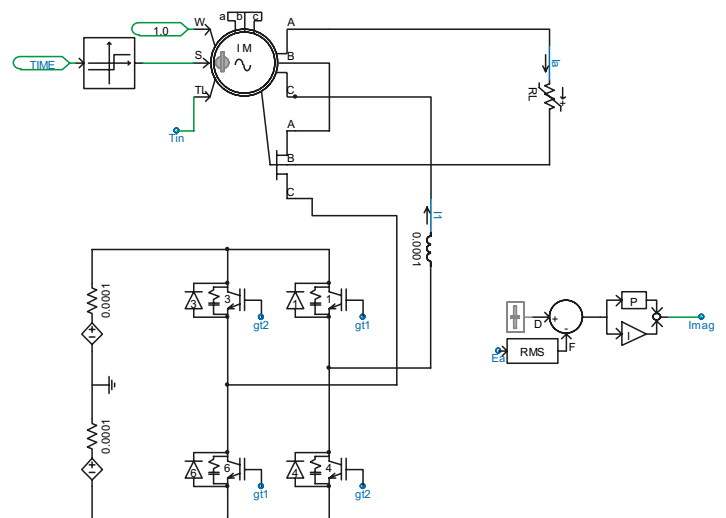

Figure 2 PSCAD® model.

Results The validity of the proposed concept was tested by simulating an existing 1 MW PSCAD® cage induction machine model, configured in the TSCAOI winding arrangement. Initially, the machine was driven as a generator at its synchronous speed. A constant generated voltage, E_{or} , of 1 p.u. was maintained by adjusting the excitation voltage, E_e . Under this condition, the machine draws just enough reactive power from the excitation source to establish the magnetization that is required to maintain the desired generated voltage. A small amount of active power is also drawn from the excitation source to overcome the resistive losses in the excitation winding. The power generated by the turbine is equal to the generated power and the other usual losses in the machine.

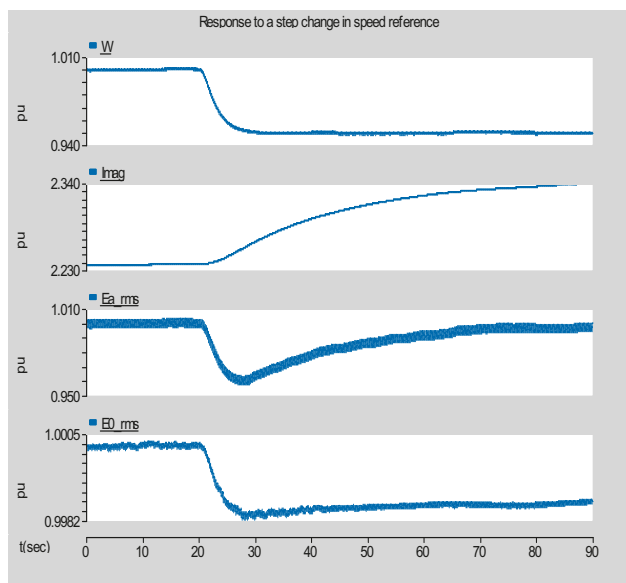

Figure 3 Waveforms of sub-synchronous operation.

As evident from Figure 3, the generator is subjected to a step reduction in speed at approximately 18 s. With this step speed change, the generator is now forced to operate at a sub-synchronous speed of 0.98 p.u. As a consequence, both load power and generated voltage drop transiently.

The load power is restored by increasing the turbine torque while the drop in generated voltage is compensated for by increasing the excitation current through the excitation voltage. There is an increase in copper losses in the excitation winding due to the increase in excitation current.

Conclusion A new 3-phase cage induction generator system, capable of generating power at constant frequency under variable rotor speed, has been described. Simulation results presented at conceptual level, indicate that constant frequency power generation without a post inverter stage, with this proposed technique, is possible. However, more detailed investigations, in relation to excitation, torque production and transient behaviour of the machine under both sub-synchronous and super-synchronous modes, are necessary to ascertain the viability of the proposed configuration. These issues are currently being investigated.

References

- [1] O. Ojo and I. Bhat; "An Analysis of Single Phase Self-Excited Induction Generators," IEEE Tran. Energy Conv., Vol. 10, No. 2, June. 1995, pp. 254-260.
- [2] Madawala, U. K., Muthumuni, D. and Bradshaw, J.; "A Novel Variable Speed Cage Induction Generator," Proceeds of IEEE Int. Conf. on Sustainable Energy Technologies – ICSET 2008, /Singapore, 24-27 Nov., 2008, pp:1250-1255.

Editor's Note:

The full patent for this concept was granted on May 28, 2009. We congratulate Dr. Madawala and his team (Electric Generator – NZ 556760).

Method for Studying and Mitigating the Effects of Wind Variability on Frequency Regulation

U.D. Annakkage, University of Manitoba

D.A. Jacobson, Manitoba Hydro

D. Muthumuni, Manitoba HVDC Research Centre

This paper presents a simulation-based approach to study the effect of wind energy variation on the frequency regulation of a power system.

In North America, the quality of frequency regulation is defined in terms of two indices known as Control Performance indices (CPS1 and CPS2). The power system is modeled as a control system with equivalent representation of turbine-governor dynamics. The system inertia is modeled as a single equivalent inertia. The power system external to the system under consideration is modeled as a single equivalent. The model is then used to study the sensitivity of CPS indices to wind variation and the settings of the Automatic Generation Controller parameters. The model also gives the amount of regulation reserves utilized in each simulated scenario.

Introduction Any mismatch of power generation and consumption in a power system leads to deviations of frequency from its nominal value. The regulating reserves are responsible in keeping the balance of power generation and consumption by maintaining the system frequency near the nominal value by adjusting their power output in response to frequency deviations. In interconnected power systems, where two or more control areas are connected through tie lines, any deviation in the frequency of one control area results in inadvertent power flow variations in the tie lines. While the interconnected areas are expected to support each other during disturbances, the control area in which the disturbance takes place is primarily responsible for adjusting its regulating reserves to take care of its own power mismatch after the initial transient period. It is important that control areas in an interconnected power system share the frequency regulation duty in an equitable manner. In North America this is measured using NERC standards known as the Control Performance Standards (CPS). There are two NERC indices, CPS1 and CPS2. These indices are defined in terms of frequency deviation and the Area Control Error (ACE). ACE is defined in terms of the frequency deviation and tie line power deviation as shown in equation (1). CPS1 measures the performance related to normal load variations and CPS2 measures the performance related to large disturbances. The ACE, CPS1, and CPS2 are defined in [1].

It can be shown that CPS1 is equal to 100% when a given area helps other areas as much as it receives help from them during disturbances. A value in excess of 100% indicates good performance. When an area receives help during generation and load imbalance, the CPS1 index deteriorates. Large unforecasted variations in wind power generation necessitate receiving help from other areas through tie line power deviations and thus, have a negative effect on the CPS1 index. This study investigates the effect of wind power generation variability on the CPS1 index.

A model of the Manitoba Hydro (MH) power system with an equivalent external system developed using PSCAD® [2] is presented with simulation results of model validation. The validated model is then used to simulate the system frequency and tie line power deviations and hence the CPS1 index. A brief outline of the developed model and the simulation studies carried out are given below. The advantage of using the PSCAD® model over a Dispatch Training Simulator (DTS) type of model is that the DTS typically calculates in real time or a bit faster than real time, whereas the PSCAD® model presented below simulates a 12-hour simulation within 5 minutes.

Load-frequency Simulation Model The inertias of all the rotating machines in the MH system (including synchronous condensers) are lumped together as a single rotating mass. The generating units are grouped into two categories for the purpose of modeling their governor and turbine responses. The units equipped with secondary frequency control (Automatic Generation Control or AGC) are modeled by a single governor-turbine model. Similarly, the remaining units are modeled by another single governor-turbine model. The power flow in the High Voltage DC (HVDC) line is modeled as a negative load added to the system. The model allows the HVDC line to be on AGC duty, in which case the AGC will generate raise/lower signals to generators on AGC, as well as the HVDC line. A simplified block diagram of the load-frequency model is shown in Figure 1. The parameter B in the block diagram is frequency bias for computing the Area Control Error (ACE). D is the load damping that represents the frequency dependency of the load.

Any deviations in MH frequency results in a deviation of tie line power flow to other areas. This is modeled using an equivalent external system comprising an inertia and damping. The tie line is modeled within the external system using an integrator with its gain representing the synchronizing coefficient of the line.

To be consistent with the NERC CPS definition, the simulated frequency deviation and tie line power deviation are sampled at four second intervals to compute the area control error (ACE). The 4.0 second sampled values of frequency and ACE are then used to compute their clock minute average values and subsequently the CPS1 for the hour according to the NERC definitions [1].

All the generators in the southern MH system can be individually switched on or off at the beginning of each simulation using switches provided in the model. The net inertia of the system is calculated based on the on-off status of generating units and synchronous condensers. The initial power set points of all the generating units and the set points of the two HVDC

bi-poles at the beginning of the hour can be entered as initial settings. The control modes of HVDC bi-poles and the units on AGC duty can also be entered using the switches provided in the model. Generating units can be tripped during the simulation. The inertia of the system is adjusted to reflect the effect of tripping of a generating unit. The model is validated using recorded data collected over the month of May in 2006. Several randomly selected one-hour intervals were used for the validation. The recorded load variation is input to the model, and the frequency deviation and tie line power deviation are simulated. The turbine and governor parameters were set at typical values. The external system was modeled as a large inertia together with damping. See [3] for more details.

The load frequency model was simulated using the control system simulation blocks available in PSCAD® software [2]. Comparisons of the system frequency and tie line power deviation for May 01, 2006, 9:00 am to 10:00 am are shown in Figure 2. It can be seen that the frequency obtained from the simulation model matched closely with that of recorded data.

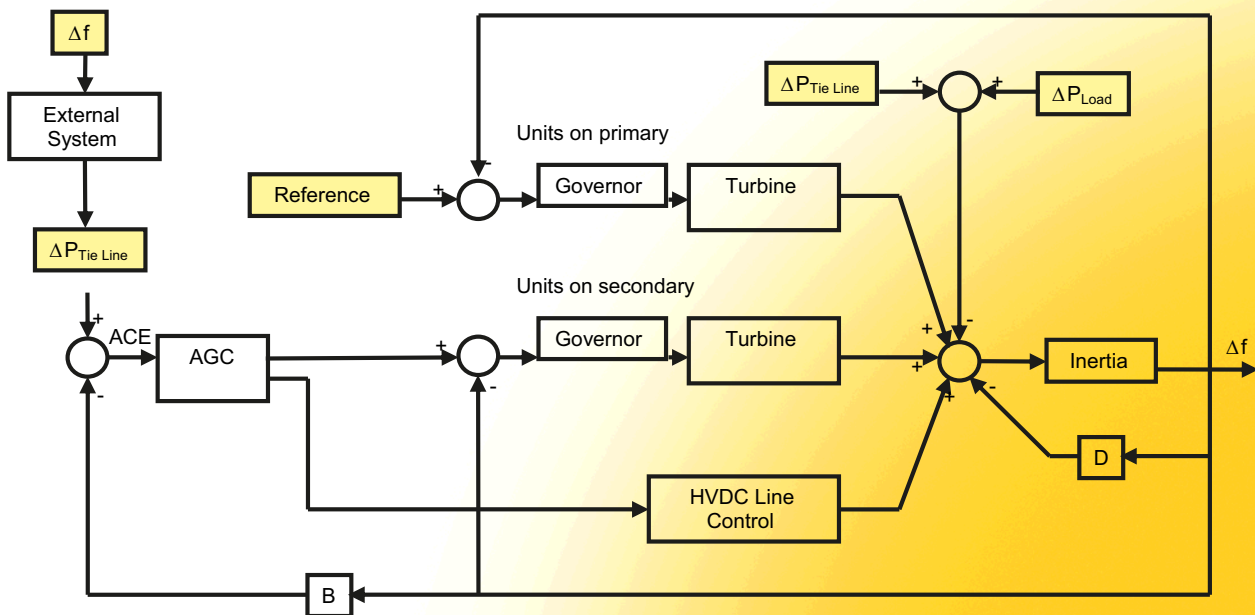

Figure 1 Manitoba Hydro load-frequency model.

A good agreement of measured and simulated tie line power was difficult to achieve because the external system model is a simplified equivalent. The model is adequate for understanding the sensitivity of control performance to various parameters.

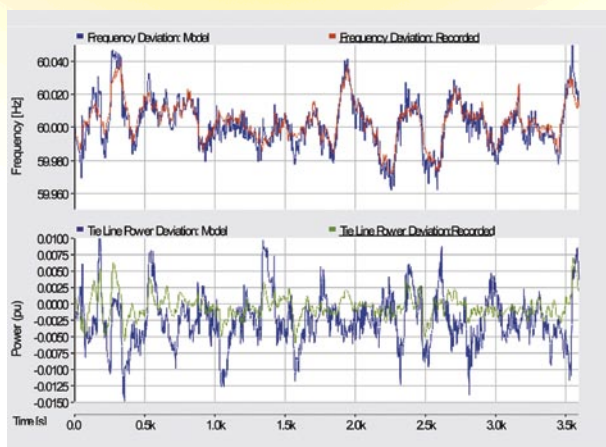

Figure 2 Comparison of simulated and recorded data for May 01, 9:00 am to 10:00 am

Simulation Results The effect of random load variations was simulated by generating a sequence of random variables with a zero mean and a desired standard deviation. This sequence was saved in a text file and input to the PSCAD® model as the system load variation. The net load is therefore equal to the initial load on the system plus the random load variations. The CPS1-one-hour (the average of 60 values of CPS1-minute) for different values of the standard deviation is shown in Table 1. As expected, the performance deteriorates as the standard deviation of random load variations increase.

Standard Deviation (MW)	CPS1_hour	Frequency Deviation Range (Hz)
10	197	59.975 — 60.024
20	191	59.594 — 60.048
30	162	59.903 — 60.071
40	156	59.902 — 60.095
50	139	59.871 — 60.134

Table 1 The effect of random load variations on the CPS1 index.

Conclusions A power system model to simulate the system frequency and tie line power exchange has been described in this paper. The model has been tuned to produce a frequency similar to recorded data. The simulations have shown that the system frequency can be closely reproduced, but the tie line power deviations are difficult to reproduce accurately. The model has been used to perform a series of sensitivity studies. Further work is underway to improve the external system representation.

Bibliography

- [1] Nasser Jaleeli and Louis S. VanSlyck, NERC's "New Control Performance Standards," IEEE Transactions on Power Systems, Vol. 14, No 3, August 1999, pages 1092-1099.
- [2] Christoph Rorthisberger, "Model Identification for Spinning Reserve Management using Non-Linear Optimization Methods," Masters Thesis, EEH Power Systems Lab, Zurich, 2006.
- [3] U.D. Annakkage, D.A. Jacobson, and D. Muthumuni, "Method for Studying and Mitigating the Effects of Wind Variability on Frequency Regulation," PES-CIGRE 2009 Joint Symposium, 29-31 July, Calgary Alberta CA

The *neXus Engine*...

Craig Muller, Manitoba HVDC Research Centre

As with many products, software is affected by the ravages of time and the ever changing expectations of the customer. The need to continually improve the software creates pressure to add newer and better features to make the experience of working with the tool an enjoyable one. Continuous development produces larger and larger implementations to meet users needs; these implementations are then placed on the back of the existing design. At some point, burdened with its ever increasing load, the supports begin to buckle under the strain. This breaking point is a recurring theme and smart development teams know when to recognize when its software reaches this juncture and take effective action.

For PSCAD®, this occurred in 2006. The increasing demand for more tools and even greater power and flexibly stretched the existing architecture to its physical limit. Adding more capabilities to the software created significant design challenges. What PSCAD® needed was a rethink; evaluating where it is to where it needs to go and come up with an entirely new approach to the strategy of system simulation without forgetting where its legacy lies. Not long after, the word *neXus* was adopted to define the new relationship PSCAD® would have with other solution tools. The concept is based on a unification model that identifies and provides a common interface between solutions through a single database model. What followed was a comprehensive and exhaustive refactoring of the entire data model in the simulation environment.

Fast forward three years to 2009. Exhaustive hours of planning, writing and experimental development have been undertaken, three versions of the software development tools, incorporation of .NET and C# assemblies, and lots of time learning and integrating new software technologies. In the process of turning a concept into real software, the database structures and software that drives it forms what is referred to as the *neXus engine*.

***neXus engine* = paradigm shift** PSCAD® is now moving on to a new generation of products. The first one in this legacy will be a new release called X4. The reason for the name is simple but significant. In essence, the next release bears a lot of similarity to its version 4 predecessor. This similarity is intentional, providing a familiar look and feel to a well established product and following with the conceptual operation of version 4.

The prefix is added to show that this product is entirely different under the hood, and the difference is the *neXus engine*.

What is the *neXus engine*? To describe it in detail is lengthy and delves into a number of different software technologies. In simpler form, it is an architectural model that places the entire application focus on a data core. If the system data is structure, then all legacy versions of PSCAD® had exoskeletons, where information was worn on the outside, visible and limited by the view or solver in which it is embedded. The *neXus engine* treats all system data as a backbone, turning PSCAD® inside out into a vertebrae. This approach separates the visualization and the solver of the system data from the system data itself. The result is a software environment where the multiple views, manipulation, and solution are operating from the same data backbone. This creates a dynamic shared environment where solvers are engines to produce new data and store it to the backbone, to then share this information with other solvers. The solvers themselves are turned into relational engines. The *neXus* backbone is self managing and is able to continuously drive the visualization. This process is the *neXus engine*.

Benefits? The long term benefits of the engine are quickly easy to see. The backbone architecture provides the ability to connect and add new functionality with no compromise to existing designs.

- In the near future, multiple solvers mean one is not limited to a single form of solution. In addition, solvers can be used to complement each other or validate against one another.
- No single view can tell the entire story. Multiple views give the user the ability to decide on that. If the schematic view is not enough to locate the results, then a simple switch will allow the user to view the information as a filtered listing.
- Steady state information from a solver can be used to initialize time domain simulation.
- Data can be protected using passwords.
- Complex designs can be built once and used many times. Hand coding is significantly reduced.

There are many new things in PSCAD® X4, too many to list here. We are very proud of this version and invite you to enjoy the benefits of this new design. If you are interested in trying the Beta version of PSCAD® X4, contact sales@pscad.com

Expanding Knowledge

The following courses are available, as well as **custom training courses** – please contact sales@pscad.com for more information.

Introduction to PSCAD® and Applications

Includes discussion of AC transients, fault and protection, transformer saturation, wind energy, FACTS, distributed generation, and power quality with practical examples. *Duration: 3 Days*

Advanced Topics in PSCAD® Simulation Training

Includes custom component design, analysis of specific simulation models, HVDC/FACTS, distributed generation, machines, power quality, etc. *Duration: 2–4 Days*

HVDC Theory & Controls

Fundamentals of HVDC Technology and applications including controls, modeling and advanced topics. *Duration: 4–5 Days*

AC Switching Study Applications in PSCAD®

Fundamentals of switching transients, modeling issues of power system equipment, stray capacitances/inductances, surge arrester energy requirements, batch mode processing and relevant standards, direct conversion of PSS/E files to PSCAD®. *Duration: 2–3 Days*

Distributed Generation & Power Quality

Includes wind energy system modeling, integration to the grid, power quality issues, and other DG methods such as solar PV, small diesel plants, fuel cells. *Duration: 3 Days*

Wind Power Modeling and Simulation using PSCAD®

Includes wind models, aero-dynamic models, machines, soft starting and doubly fed connections, crowbar protection, low voltage ride through capability. *Duration: 3 Days*

Industrial Systems Simulation & Modeling

Includes motor starting, power quality, capacitor bank switching, harmonics, power electronic converters, arc furnace, protection issues. *Duration: 1–2 Days*

Lightning Coordination & Fast Front Studies

Substation modeling for a fast front study, representing station equipment, stray capacitances, relevant standards, transmission tower model for flash-over studies, surge arrester representation and data. *Duration: 2 Days*

Modeling and Application of FACTS Devices

Fundamentals of solid-state FACTS systems. System modeling, control system modeling, converter modeling, and system impact studies. *Duration: 2–3 Days*

Connect with Us!

July 26–30, 2009

IEEE 2009 General Meeting

www.ieee.org/power

Calgary, Alberta CANADA

More events are planned! Please see www.pscad.com for more information.

PSCAD® Training Sessions

Here are a few of the training courses currently scheduled. Additional opportunities will be added periodically, so please see www.pscad.com for more information about course availability.

September 8–10, 2009

Introduction to PSCAD® and Applications

September 15–17, 2009

Wind Power Modeling and Simulation using PSCAD®

October 27–29, 2009

Modeling and Applications of FACTS Devices

November 17–19, 2009

HVDC Theory and Controls

All training courses mentioned above are held at the Manitoba HVDC Research Centre Inc. Winnipeg, Manitoba, Canada
sales@pscad.com www.pscad.com

Please visit Nayak Corporation's website www.nayakcorp.com for courses in the USA.

July 14–16, 2009

Introduction to PSCAD® and Applications

Princeton, New Jersey USA

October 20–22, 2009

Introduction to PSCAD® and Applications

Princeton, New Jersey USA

For more information on dates, contact info@pscad.com today!

If you have interesting experiences and would like to share with the PSCAD® community in future issues of the *Pulse*, please send in your article to info@pscad.com

